

Kod wyrobu:  
 W-CR-0000061 + W-CR-000064 +  
 W-CR-000065

Nazwa wyrobu:  
**SNC2 + Przedłużenia**

Waga: 200,1 kg

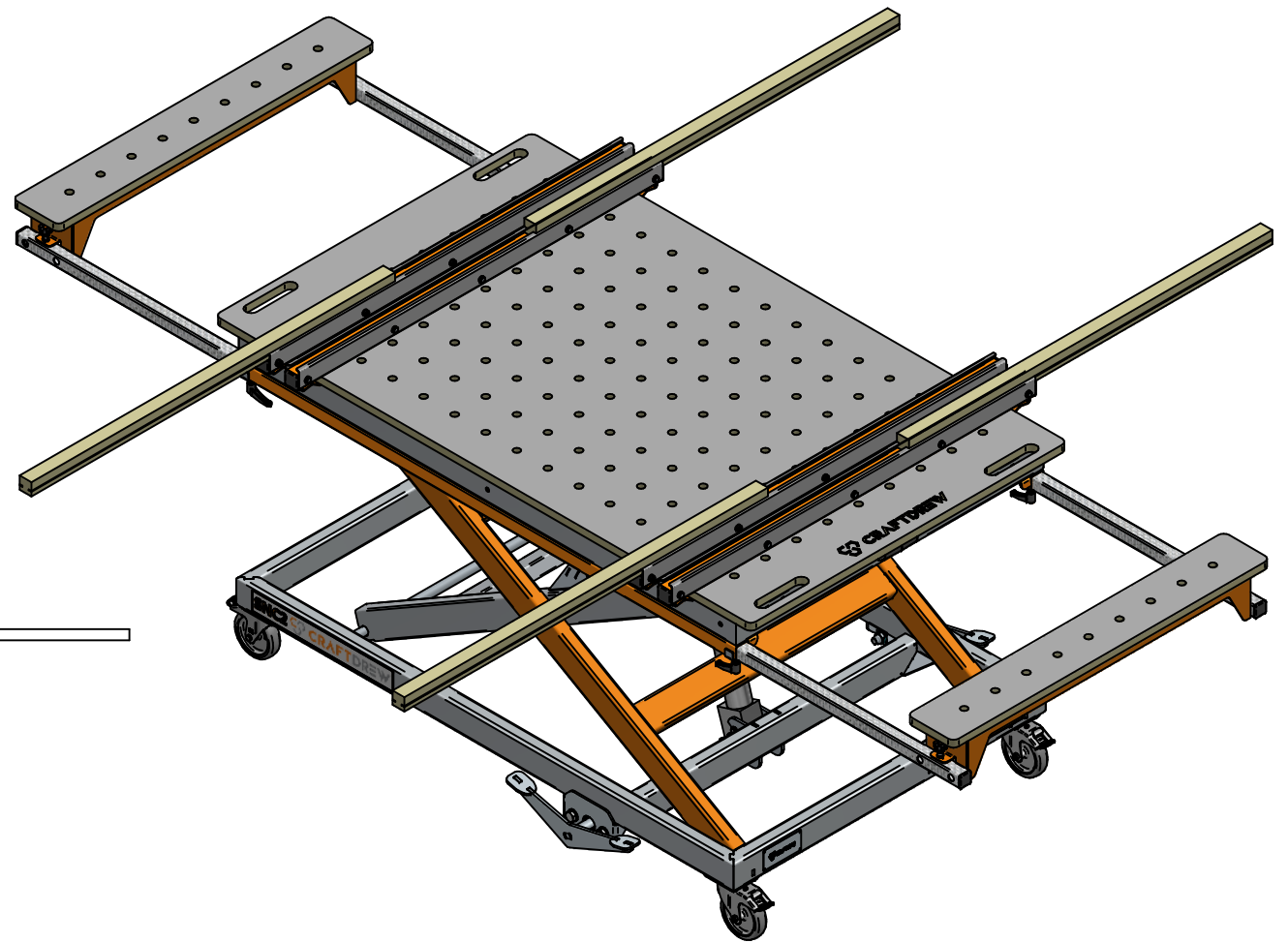
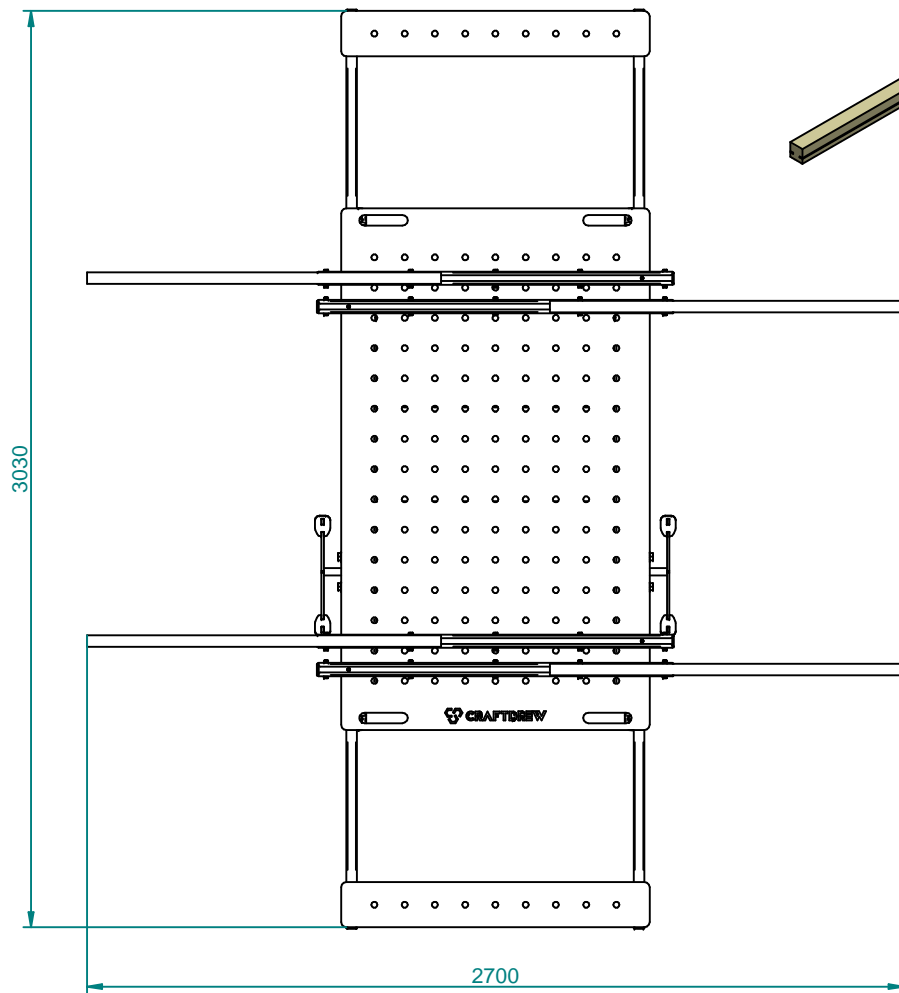

Kod wyrobu:  
W-CR-0000061 + W-CR-000064 +  
W-CR-000065

Nazwa wyrobu:  
SNC2 + Przedłużenia

Waga: 200,1 kg